

5.12 DURABILITY

5.12.1 General

All State and Locally sponsored projects shall be required to provide a deck protection system in the design and construction on all new concrete bridge decks, regardless of the winter roadway maintenance salt policy. Both mats of reinforcing steel should be considered for epoxy coating in deck slabs that will be carrying high volumes of traffic and will be subjected to frequent winter salting applications. Since both high traffic and frequent salting will occur primarily in urban areas, all structures located in urban areas shall be evaluated for a dual protection system.

A Single Deck Protection System is the minimum acceptable deck protection for decks exposed to traffic on all interstate, state, or county highways unless additional deck protection is required. The single deck protection system shall meet the requirements listed below. The type of deck protection system shall be shown or noted on the Situation and Layout Drawing.

EXPOSED DECK SLAB

The deck slab is considered exposed to traffic when the distance between the finished grade and the top of the concrete deck is less than 4 inches between the paved roadway shoulders.

SINGLE DECK PROTECTION SYSTEM

- The concrete deck shall have an 8-inch minimum thickness of Class 40A concrete, which includes a ½ inch expendable wearing surface that is considered as added dead load and not having structural capabilities.
- The top mat of reinforcement shall have 2½ inches of cover.
- All reinforcement within 4 inches of surfaces exposed to traffic shall be epoxy coated, including concrete parapets.

DUAL DECK PROTECTION SYSTEM

A dual deck protection system shall be utilized for all structures requiring special construction techniques or that have been classified as major or unusual bridges. Any structure that will require shoring for removal and repair of the deck (e.g. CIP box girders, CIP tee beams, CIP slab bridges) shall have a dual protection system. Deck slabs on box girder bridges are difficult and costly to repair unless the deck is designed so a portion of the deck can be removed without requiring shoring, such as the Type 1 dual deck protection system.

The dual deck protection system shall meet the requirements listed for one of the 3 following types. The type selected will require the approval of the Bridge Design Engineer prior to incorporating that system in the design.

TYPE 1

- The concrete deck shall have a 7½ inch minimum thickness of Class 40A concrete, which does not include the 1½ inch of replaceable wearing surface that is considered as added dead load and not having structural capabilities.
- The top mat of reinforcement shall have 1¾ inches initial cover (before scarification of ¼ inches).
- The deck shall be designed so that the top 1½ inches can be removed without requiring shoring while maintaining traffic on a portion of the deck. The replaceable wearing surface of 1½ inches shall be latex modified concrete or micro silica modified concrete.
- All reinforcement within 4 inches of surfaces exposed to traffic shall be epoxy coated, including concrete parapets.

TYPE 2

- The concrete deck shall have an 8½-inch minimum thickness of Class 40A concrete, which includes a 1-inch expendable wearing surface that is considered as added dead load and not having structural capabilities.
- The top mat of reinforcement shall have 3 inches of cover.
- All reinforcement within 4 inches of surfaces exposed to traffic shall be epoxy coated, including concrete parapets.

TYPE 3

- Bridges using precast prestressed boxes or slabs as the deck to support traffic shall use the Type 3 Dual Deck Protection System. The concrete class and member sizes for precast, prestressed deck members shall be determined by design.
- The top mat of reinforcement shall have 2½ inches of cover.
- The top surface of precast beams that act as the bridge deck shall have an asphalt overlay of 1¾ inches with an interlayer waterproofing membrane. Prior to placement of the membrane, all joints between precast units that exceed ¼ inch difference in elevation shall be over grouted to accommodate hand finishing. The grouted slopes

shall not be greater than 1:12.

- All reinforcement within 4 inches of surfaces exposed to traffic shall be epoxy coated, including concrete parapets.

BURIED DECK SLABS

The deck slab is considered buried when the distance between the finished grade and the top of the concrete deck is greater than 4 inches between the paved roadway shoulders. This generally applies to box culverts and stifflegs where roadway ballast is carried over the top slab.

UNDER ROADWAY WITH LESS THAN 2 FEET FILL

- The deck slab shall be Class 40A concrete with a waterproof membrane applied as specified in Section 511 of the Standard Specifications.
- The top mat of reinforcement shall have 2½ inches of cover.
- Both mats of reinforcement in the deck slab shall be non-epoxy coated bars.

OUTSIDE ROADWAY OR FILL EXCEEDS 2 FEET

- The deck slab shall be Class 40B concrete.
- The top mat of reinforcement shall have 2 inches of cover.
- Both mats of reinforcement in the deck slab shall be non-epoxy coated bars.

ELECTRICAL CONNECTION TO BRIDGE DECK REINFORCEMENT

The following is standard practice for locating electrical test connection points on the edges of new concrete bridge decks. CADDs cell on B5.7 is available for use on the plans.

PLAIN & EPOXY COATED REINFORCEMENT

Each deck section shorter than 250' should have two connection points. These connections should be located at the extreme ends of the deck section, within 3' of the ends of the deck section. The connections should be located on opposite sides of the deck.

On decks greater than 250', electrical connection points should be evenly spaced, but no more than 250' apart. Locations should alternate between opposite edges of the deck. Spacing should be adjusted so that there is a connection point within 3' of each end of the deck section.

A deck section is defined as a portion of deck where the longitudinal reinforcement is continuous throughout. The section ends at any point where there is a transverse joint if the longitudinal reinforcement does not pass through the joint. At a construction joint, where longitudinal steel is carried through the joint, the deck on both sides of the joint is part of a single, continuous deck section for electrical testing purposes.

CATHODIC PROTECTION

On decks designed for cathodic protection, connection points shall be installed in the same locations as for ordinary reinforcement. In addition, some means must be provided to break the cathodic protection circuit so that readings can be taken with the protective current shut off.

PRECAST PRESTRESSED SLABS

Electrical connection points are not required for precast, prestressed slab bridges and deck bulb-tee bridges.

Revisions:

June 2006 Added paragraph for Electrical Connections to Bridge Decks that was in the ITD Bridge Metric/English Manuals.

DECK PROTECTION SYSTEM DETAILS FOR NEW CONCRETE BRIDGE DECKS

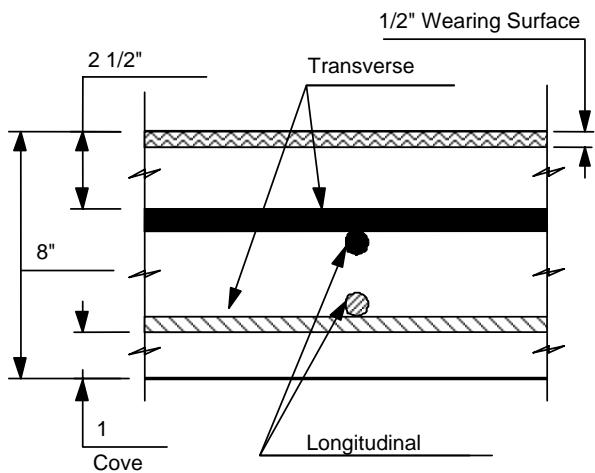

SINGLE PROTECTION SYSTEM

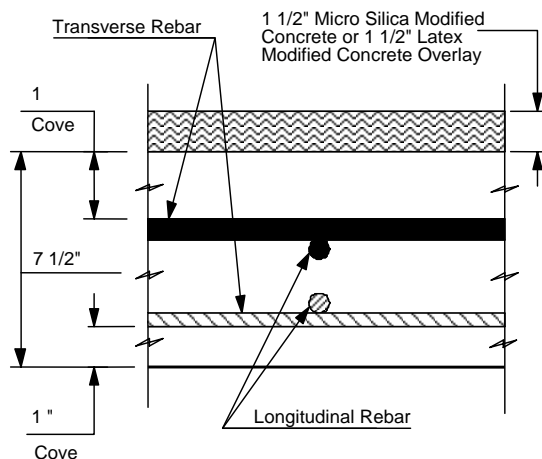

**TYPE I
 DUAL PROTECTION SYSTEM**

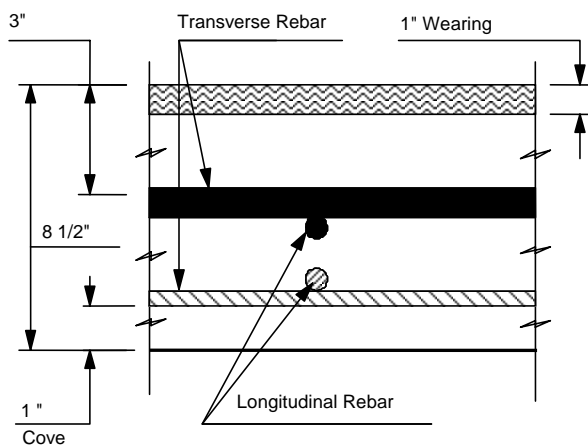

**TYPE 2
 DUAL PROTECTION SYSTEM**

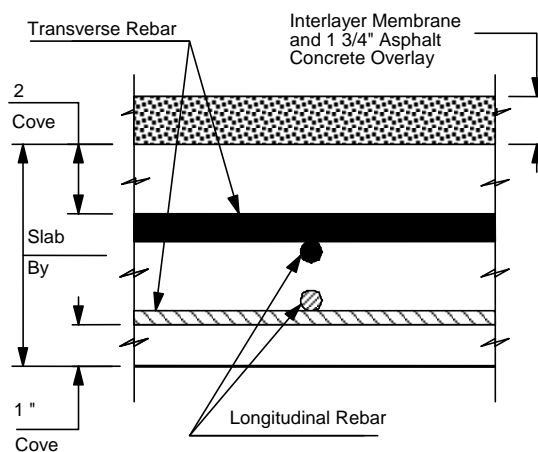

**TYPE 3
 DUAL PROTECTION SYSTEM**

Epoxy Coated Reinforcement



Non Coated Reinforcement

